

# HG-200SG-3

**GLADEN**  
GERMAN TECHNOLOGY

Loudspeaker data sheet

## Specifications

### Woofer

Impedance	3,0	$\Omega$
Power handling	130/70	Watt/Wrms
Minimum amplifier power	25	Wrms
Recommended frequency area	50-5000	Hz
SPL (2,83V/1m)	94,4	dB

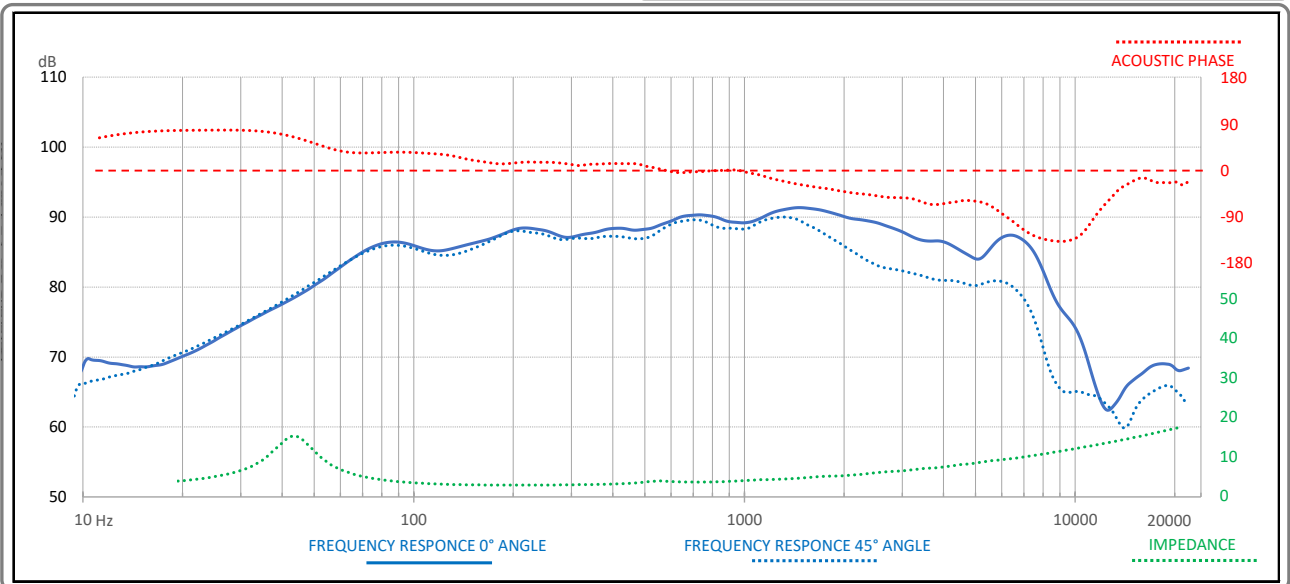

## Parameters

DC resistance	Rdc	2,5	$\Omega$
Resonance frequency	fs	44,77	Hz
Mechanical quality	Qms	3,07	
Electrical quality	Qes	0,61	
Total quality	Qts	0,51	
Equivalent volume	VAS	37,53	Liter
Dynamically moving mass	Mms	22,2	g
Effective membrane area	Sd	216,4	cm <sup>2</sup>
Mechanical resistance	Rms	2,03	Kg/s
Mechanical compliance	Cms	0,570	mm/N
Electromagnetic force	BL	5,0	Tm
Sensitivity (1W/1m)	SPL	89,3	dB
EBP		73	
Voice coil diameter	VCD	28	mm
Maximum linear excursion	Xmax +/-	4	mm
Weight net		1,20	kg

## Dimensions

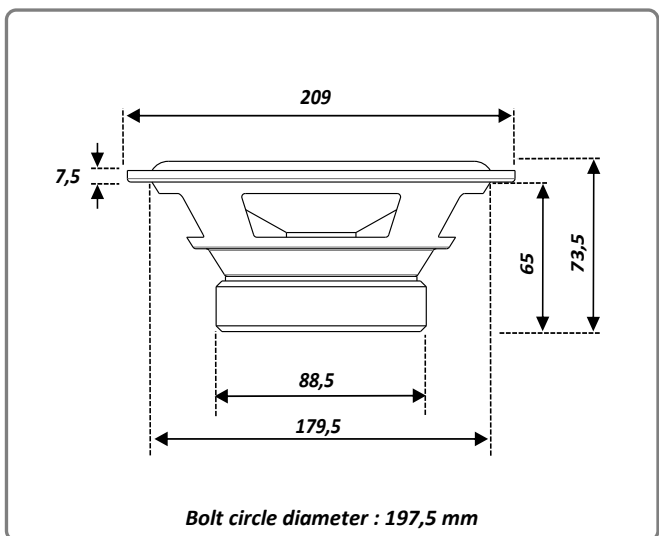

## Housing suggestions

sealed

vented

bandpass (4th)

bandpass (6th)

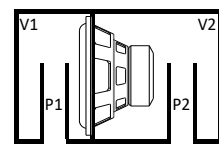
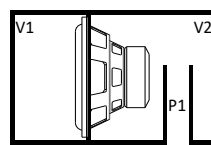
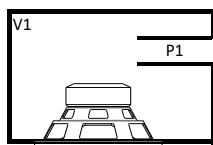
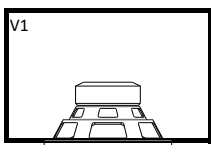

Volume (V) in liters, dimensions port (P) in mm (diameter (D) and length (L))

All data without guarantee. Data can vary. Check data before assembly and operation.

GLADEN EUROPE GmbH - Bertha-Benz-Strasse 9 - 72141 Walldorfhäsloch - CEO Alexandra Gladen - info@gladen.com